

외형도(External Figure)

HCP-60S~250S

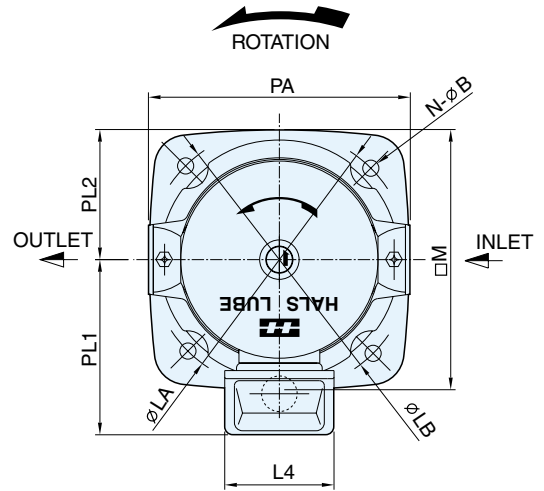

HCP-400S

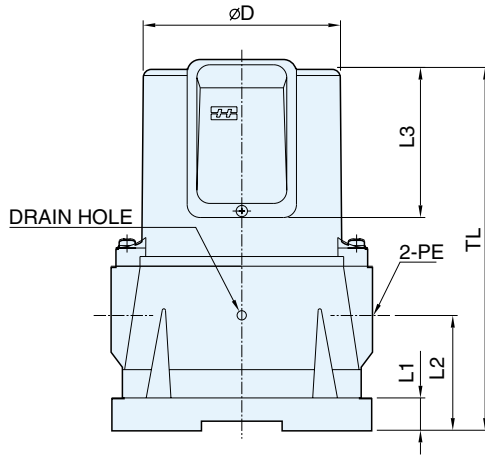
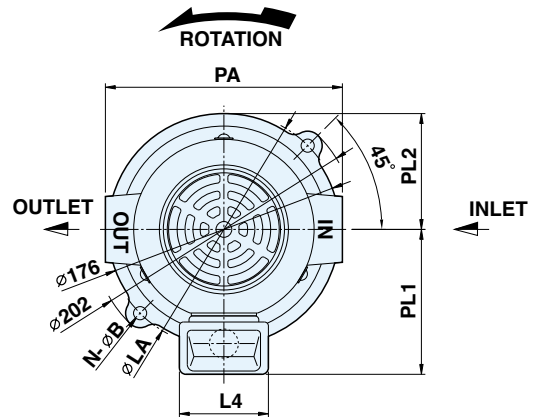
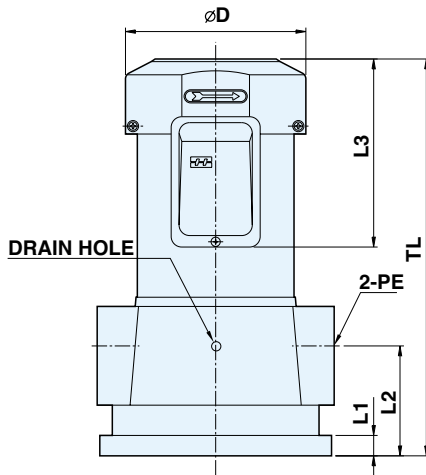

외형치수(Dimension)

형식	구분	ø D	L1	L2	L3	L4	PE(PT)	TL	LA	LB	N-ø B	PA	M	PL1	PL2
HCP-60S		94	15	56	92.5	67.6	2-3/8	200	132 (132)	150 (150)	4-7	132	130	93.5	65
HCP-100S		94	15	56	92.5	67.6	2-3/8	200	132 (132)	150 (150)	4-7	132	130	93.5	65
HCP-120S		94	15	56	92.5	67.6	2-3/8	200	132 (132)	150 (150)	4-7	132	130	93.5	65
HCP-180S		121	15	63	93	67.6	2-1/2	224.5	167 (160)	170 (164)	4-10	162	160	108.5	83
HCP-250S		121	20	71	93	67.6	2-3/4	230	167 (160)	170 (170)	4-10	162	160	108.5	83
HCP-400S		137	15	85	143	67.6	2-1	303	180 (180)	-	2-10	180	-	110	88

* LA, LB항 () 안의 치수는 수출용임